



## **Math Workshop Prealgebra/Numerical Skills**

**Workshop Objective:** Once a student successfully completes the Prealgebra Math Workshop, s/he will achieve a basic understanding the material taught in a MAT 047 course offered at Oakton. Students will be offered the skills and knowledge required of them to demonstrate competency on the Math Placement Test in any of the topics covered during the workshop.

**Workshop Topics:** Integers, Fractions, Decimals, Square Roots, Scientific Notation, Absolute Value, Order of Operations, Ratio and Proportion, Percentages, Average (arithmetic mean), Median, Mode, Algebraic Expressions, Linear Equations in One Variable, Basic Geometry Skills (Perimeter, Area, Volume), Pythagorean Theorem, The Cartesian Coordinate System, Applications.

**Workshop Overview:** The workshop will identify and explain all of the various topics listed above. The topics covered during the workshop are found on the Oakton Math Placement Test. The supplementary exercises provided are a review of what a student would expect to learn in a MAT 047 course. **Any exercise sets labeled with an asterisk (\*) are additional topics not necessarily found on the Math Placement Test.**

Once a student feels confident with all of these workshop topics, then another, more advanced Math Workshop is recommended. A student may re-take any workshop. Each student has an opportunity to re-take the Math Placement Test one time, if they are not satisfied with their test performance. Please feel free to discuss any of your concerns with your Math Workshop instructor. This workshop is not intended to be a substitute for taking/completing MAT 047 over a normal semester setting. Command in the topic material, and supplementary exercises, is not a guarantee that a student has qualified to place into a higher math course (above MAT 047). However, if a student does have a solid understanding of the topics covered, then that student should place into a higher math course (above MAT 047).

# Numerical Skills

## Integers

### Add/Subtract

Simplify

1)  $23 + 45 + 67$

2)  $-2 + 8 + (-12)$

3)  $23 + (-43) + 16$

4)  $-19 + (-40) + 40$

5)  $11 - 34 - (14)$

6)  $-10 - 20 - 40$

7)  $3 - (-6) - (-16)$

8)  $-19 + 45 - 15$

### Multiply/Divide

Simplify

1)  $(-2)(-16)$

2)  $(10)(-5)(4)(-1)(0)$

3)  $(10)(-10)(-10)(-2)$

4)  $(-1)(-1)(-1)(-1)(-1)$

5)  $-23 \times 47$

6)  $345 \times 123$

7)  $(-12) \div 0$

8)  $-51 \div (-3)$

9)  $25 \div (-5)$

10)  $0 \div (-100)$

## Fractions

### Add/Subtract

Simplify

$$1) \frac{2}{3} + \frac{1}{3}$$

$$2) \frac{1}{2} + \frac{1}{2}$$

$$3) \frac{1}{4} + \frac{1}{5}$$

$$4) \frac{2}{7} + \frac{3}{8}$$

$$5) \frac{5}{25} - \frac{3}{27}$$

$$6) \frac{8}{7} + \left[ -\frac{4}{3} \right]$$

$$7) \frac{5}{18} - \frac{3}{21} + \frac{1}{27}$$

$$8) \frac{2}{36} + \left( \frac{3}{16} \right) + \left( -\frac{5}{4} \right)$$

**Multiply/Divide**  
Simplify

1)  $\left(\frac{2}{3}\right) \times \left(\frac{3}{5}\right)$

2)  $\frac{6}{25} \times \left(-\frac{10}{30}\right)$

3)  $\frac{2}{9} \times \frac{6}{14} \times \frac{7}{8}$

4)  $\frac{3}{4} \div \frac{3}{4}$

5)  $-\frac{1}{2} \div \frac{5}{6}$

6)  $\frac{7}{12} \div \left(-\frac{5}{6}\right)$

7)  $\frac{\left(\frac{1}{4}\right)}{\left(\frac{2}{3}\right)}$

8)  $\frac{3}{4} \times \frac{16}{3} \times \frac{5}{4}$

## Decimals

### Add/Subtract

Simplify

1)  $12.345 + 981.7$

2)  $45.62 - 9.007$

3)  $2354 - 34.993$

4)  $34.56 + 67.9003 + 0.934$

### Multiply/Divide

Simplify

1)  $34.12 \times 2.3$

2)  $(-45.46) \times (-12)$

3)  $87.11 \times (-45.71)$

4)  $12.6 \div 0.12$

5)  $5 \div 0.005$

6)  $0.045 \div (-9)$

## Exponents

Simplify

1)  $2^2$

2)  $-2^2$

3)  $(-2)^2$

4)  $(-5)^3$

5)  $10^6$

6)  $8^0$

7)  $-8^0$

## Square Roots

Find the exact square root.

1)  $\sqrt{16}$

2)  $\sqrt{0}$

3)  $\sqrt{1}$

4)  $\sqrt{100}$

5)  $\sqrt{25}$

6)  $\sqrt{49}$

Round to the nearest hundredth.

7)  $\sqrt{2}$

8)  $\sqrt{19}$

## \*Scientific Notation and Standard Form

Write in scientific notation.

1) 3,430,000,000

2) 0.0009846

Write in standard form.

3)  $2.10 \times 10^{-5}$

4)  $8.59 \times 10^6$

## Absolute Value

Simplify.

1)  $|0|$

2)  $|-5|$

3)  $|5|$

4)  $-|-5|$

## Order of Operations

Simplify

1)  $4 - 2 + 2$

2)  $4 \div 2 \times 2$

3)  $4 + 3^2 \div 5$

4)  $-25 \div 4^2 - 3^2$

5)  $50 - 6 \div 3 \times 5$

6)  $\left(\frac{2}{3} - \frac{4}{5}\right)^2 \div \left(\frac{1}{3} \times \frac{2}{5}\right)$

7)  $\frac{1}{2} + \left[2\left(4 - \frac{4}{5}\right) - \frac{1}{5}\right]$

8)  $\frac{6}{9} \div \left(\frac{2}{7} + \frac{4}{5} \times \frac{2}{7}\right)$

9)  $4 - 3 \cdot 3^2 + 5 \div 7$

10)  $14 + 6 \cdot 1 - 2[4 + 5 \cdot 4 - 7^2]$

11)  $|-5 - 3| - |-2|$

12)  $|-4^2 - 9|$

## Ratio and Proportion

Solve

1)  $\frac{x}{5} = \frac{2}{5}$

2)  $\frac{x}{8} = -\frac{16}{40}$

3)  $\frac{4}{x} = \frac{15}{16}$

4)  $\frac{1}{3} = \frac{15}{x}$

# Percentages

Write as a percent. Round to the nearest hundredth of a percent, if necessary.

1) 0.35

2) 0.05

3) 1

4) 2.5

5) 0.0045

6)  $\frac{2}{3}$

7)  $\frac{1}{4}$

8)  $\frac{1}{9}$

9)  $4\frac{5}{6}$

Write as a decimal. Round to the nearest thousandth, if necessary.

10) 45%

11) 2%

12) 130%

13) 0.25%

14)  $\frac{4}{5}\%$

15)  $20\frac{1}{4}\%$

Find the following. Round to the nearest tenth of a percent, if necessary.

16) What is 20% of 50?

17) 30 is what percent of 90?

18) 12 is 250% of what?

## \*Average (Arithmetic Mean), Median, Mode

Find the average/mean of the following sets of numbers.

1) 90, 86, 59, 85, 96

2) 1, 2, 3, 4, 5

Find the median and mode of the following sets of numbers.

3) 3, 6, 8, 3, 5, 1, 3, 2, 3, 2

4) 24, 65, 40, 21, 24, 40

## Algebraic Expressions

Simplify

1)  $2x + 4x$

2)  $4 - 5x$

3)  $-3 - 12x$

4)  $4x - 5x + 3$

5)  $7 - 5x + 16x - 14$

6)  $2x + 4y$

7)  $4x - 5 + 3x + 4$

8)  $-4 - 7 - x - x - 4$

9)  $-x + 7 + 4 - 5x$

10)  $4 - 3x + 4$

11)  $\frac{2}{3} \left( \frac{3}{2}x \right)$

12)  $-\frac{1}{5} - 15x$

13)  $\frac{x}{5} + \frac{3x}{5}$

14)  $\frac{4}{5} - \frac{x}{5} + \frac{2}{3} - \frac{4}{5}x$

15)  $4.5x - 3.2x + 6.5 - 11.4$

Evaluate. Given  $x = -3$ ,  $y = 5$ ,  $z = \frac{3}{4}$ ,  $a = -\frac{1}{2}$ , and  $b = 4.5$ .

16)  $4x - 2y$

17)  $xyz$

18)  $x^2$

19)  $-x^3$

20)  $xy \div z$

21)  $2b^2$

22)  $yz + b$

23)  $a + b + x + y + z$

## Linear Equations in One Variable

Solve

1)  $y - 5 = 12$

2)  $2x - 5x = 7 - 14$

3)  $\frac{1}{2} 4x - 6 + 10 = \frac{4}{5} 15x$

4)  $5.6x - 2.4 = 2.3x + 1.5$

5)  $-\frac{6}{7}x = -42$

6)  $-4t - 5 + 10 = 6t - 5 + 20$

7)  $\frac{x-5}{4} = \frac{(x-6)}{2}$

8)  $\frac{y}{4} = 16$

9)  $\frac{x}{15} + 2 = \frac{7}{3}$

10)  $-2 - 4(x+5) + 8 = 3(x-6)$

# \*Basic Geometry Skills

## Rectangles, Triangles, and Circles

Find the Perimeter or Circumference, and Area of the following shapes.

1) *Rectangle*

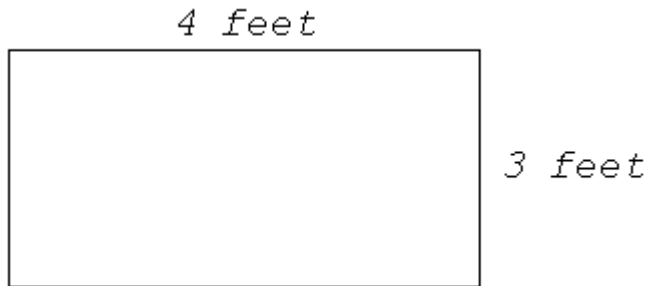

2) *Triangle*

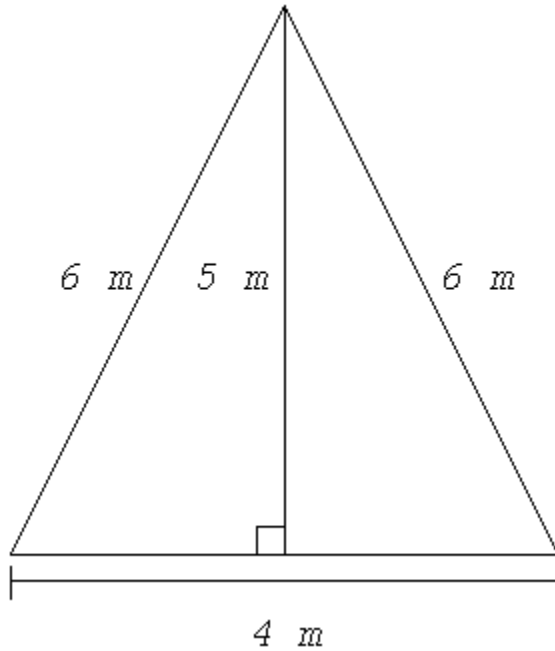

3) *Circle*

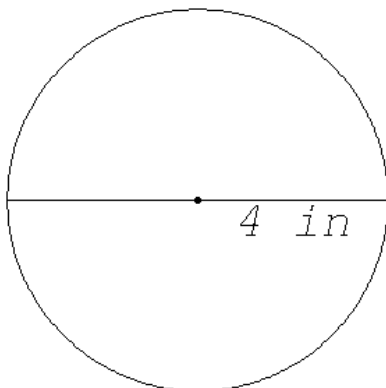

Find the volume of the following shapes.

4)

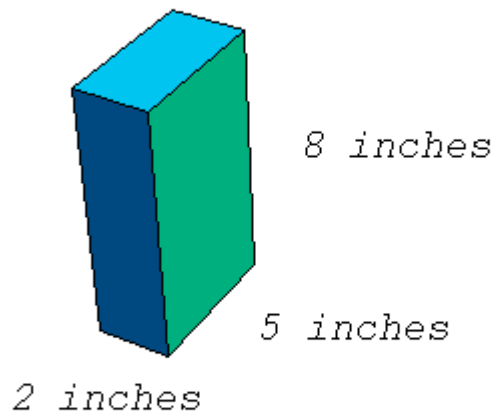

5)

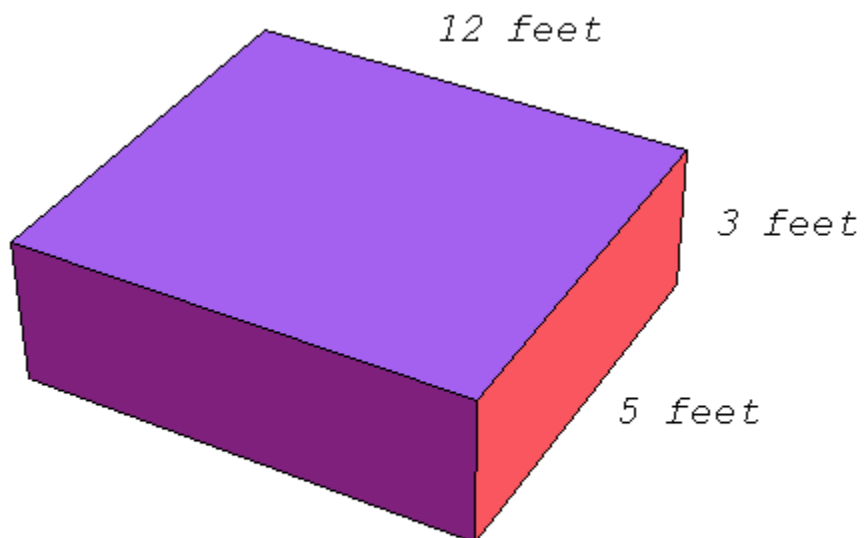

# Pythagorean Theorem

Solve for the missing side of the following right triangles.

1)

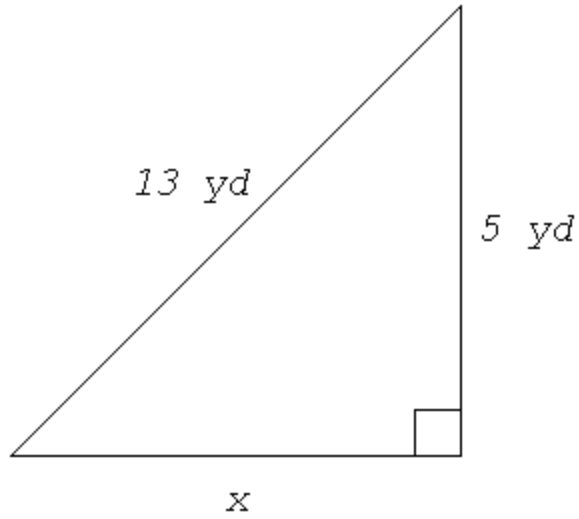

2)

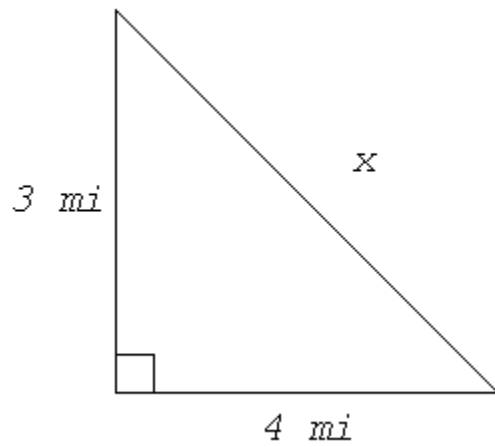

## \*The Cartesian Coordinate System

1) Plot the following points:

- a) (2,3)
- b) (-1,2)
- c) (-4,-5)
- d) (6,0)
- e) (3,-1)
- f) (0,-3)

2) Graph the following linear equations:

- a)  $2x - y = 6$
- b)  $y = 4x$

## Applications

- 1) On an early winter morning in Chicago the temperature was recorded to be  $14^{\circ}\text{F}$ . Later that day the temperature was recorded to be  $-9^{\circ}\text{F}$ . What was the temperature decrease in degrees Fahrenheit?
- 2) Mr. T went to the local Jewel to grocery shop. He bought 5.25 pounds of chicken,  $3\frac{3}{4}$  pounds of skirt steak, and  $2\frac{1}{2}$  pounds of turkey. How much meat did he buy in total?
- 3) If  $16 < \sqrt{x} < 25$ , then what two integers is  $x$  between?
- 4) There are 15 students in a math workshop. If 40% of the students are men, how many of them are female?
- 5) There are 150 students in a huge lecture classroom. 24% of the class was absent. How many students were absent?
- 6) John earned a total of  $x$  points after taking 5 tests in his Prealgebra class. To calculate his average score he divided his total points by 4, which was 88. What should John's actual average be?
- 7) There are 45 people waiting in line to purchase their items at an electronics store. After waiting for some time, 20% of the people leave the line after 5 minutes. Then after another 5 minutes, another 25% of the people leave the line. How many people are in the line now? How many people left? How many people can we expect to leave after another 5 minutes?
- 8) A class of 25 women and 30 men took a test. The average test score for the women is 75 and 82 for the men. What was the class average for all 55 students?
- 9) Jim owns his own hotdog stand. He pays \$0.45 for each hotdog he sells at \$1.25. At least how many hotdogs does he have to sell to make a profit of \$52?
- 10) Gloria has \$344.60 in her savings account before she earns \$0.60 in interest at the end of the month. What is her annual interest rate? (Round to the nearest percent.)

- 11) Bob had \$43.20 in his checking account. He then charged \$57.88 on his checking debit card while out for dinner. What will his new balance be?
- 12) If it costs \$5.50 for 20 apples, how much will it cost for 30 apples?
- 13) To fill a cars gas tank, 15 gallons of gas, it costs \$45. An economy car gets 375 miles per full tank of gas. How much will 12 gallons of gas cost? How many miles will 12 gallons get?
- 14) John drives up north where the gas is cheaper. He buys gas at \$2.56 per gallon. When he left Chicago, gas was \$3.25 per gallon. If he buys 12 gallons of gas at the cheaper price, how much does he save?
- 15) Which is larger  $\frac{13}{15}$  or  $\frac{3}{4}$  ?
- 16) Which is larger  $\frac{4.5}{\left(\frac{1}{5}\right)}$  or  $\frac{3.5}{\left(\frac{2}{3}\right)}$  ?
- 17) Translate the following sentences into an equation and solve.  
Let x represent "a number".
- a) Four more than twice a number equals six less than that number.
  - b) Three less than a number is four times the sum of that number and eight.
  - c) The quotient of a number and negative four is nine less than half that number.
  - d) Nine times the product of a number and two is forty less that number.

Created by: Ivan Temesvari

# Prealgebra Math Workshop Solutions

## Numerical Skills

### Integers

#### Add/Subtract

- 1) 135
- 2) -6
- 3) -4
- 4) -19
- 5) -37
- 6) -70
- 7) 25
- 8) 11

#### Multiply/Divide

- 1) 32
- 2) 0
- 3) -2000
- 4) -1
- 5) -1081
- 6) 42435
- 7) undefined
- 8) 17
- 9) -5
- 10) 0

### Fractions

#### Add/Subtract

- 1) 1
- 2) 1
- 3)  $\frac{9}{20}$
- 4)  $\frac{37}{56}$
- 5)  $\frac{4}{45}$
- 6)  $-\frac{4}{21}$
- 7)  $\frac{65}{378}$
- 8)  $-\frac{145}{144}$

#### Multiply/Divide

- 1)  $\frac{2}{5}$
- 2)  $-\frac{2}{25}$
- 3)  $\frac{1}{12}$
- 4) 1
- 5)  $-\frac{3}{5}$
- 6)  $-\frac{7}{10}$
- 7)  $\frac{3}{8}$
- 8) 5

### Decimals

#### Add/Subtract

- 1) 994.045

- 2) 36.613
- 3) 2319.007
- 4) 103.3943

**Multiply/Divide**

- 1) 78.476
- 2) 545.52
- 3) -3981.7981
- 4) 105
- 5) 1000
- 6) -0.005

**Exponents**

- 1) 4
- 2) -4
- 3) 4
- 4) -125
- 5) 1,000,000
- 6) 1
- 7) -1

**Square Roots**

- 1) 4
- 2) 0
- 3) 1
- 4) 10
- 5) 5
- 6) 7
- 7) 1.41
- 8) 4.36

**Scientific Notation**

- 1)  $3.43 \times 10^9$
- 2)  $9.846 \times 10^{-4}$
- 3) 0.000021
- 4) 8,590,000

**Absolute Value**

- 1) 0
- 2) 5
- 3) 5
- 4) -5

**Order of Operations**

- 1) 4
- 2) 4
- 3) 20
- 4)  $-25/49$
- 5) 40
- 6)  $2/15$
- 7)  $67/10$
- 8)  $35/27$

- 9)  $-2$
- 10)  $-568$
- 11)  $6$
- 12)  $25$

#### Ratio and Proportion

- 1)  $x = 2$
- 2)  $x = -16/5$
- 3)  $x = 64/15$
- 4)  $x = 45$

#### Percentages

- 1)  $35\%$
- 2)  $5\%$
- 3)  $100\%$
- 4)  $250\%$
- 5)  $0.45\%$
- 6)  $66.67\%$
- 7)  $25\%$
- 8)  $11.11\%$
- 9)  $483.33\%$
- 10)  $0.45$
- 11)  $0.02$
- 12)  $1.3$
- 13)  $0.0025$
- 14)  $0.0020$
- 15)  $0.2025$
- 16)  $10$
- 17)  $33.3\%$
- 18)  $4.8$

#### Average, Median, Mode

- 1)  $83.2$
- 2)  $3$
- 3) mode = 3, median = 3
- 4) mode = {24,40}, median = 32

#### Algebraic Expressions

- 1)  $6x$
- 2)  $20x$
- 3)  $-36x$
- 4)  $-1x + 3$
- 5)  $11x - 7$
- 6)  $2x + 4y$
- 7)  $7x - 24$
- 8)  $3x - 24$
- 9)  $-6x - 3$
- 10)  $-3x - 8$
- 11)  $x$
- 12)  $-3x$

- 13)  $4x/5$
- 14)  $22/15 - x$
- 15)  $1.3x - 4.9$
- 16)  $-22$
- 17)  $-45/4$
- 18)  $9$
- 19)  $27$
- 20)  $-20$
- 21)  $40.5$
- 22)  $8.25$
- 23)  $6.75$

#### Linear Equations in One Variable

- 1)  $y = 17$
- 2)  $x = 7/3$
- 3)  $x = 7/10$
- 4)  $x = 13/11$
- 5)  $x = 49$
- 6)  $t = 4$
- 7)  $x = 7$
- 8)  $y = 64$
- 9)  $x = 5$
- 10)  $x = 4/7$

#### Basic Geometry Skills

- 1)  $P = 14$  ft,  $A = 12$  ft<sup>2</sup>
- 2)  $P = 16$  m,  $A = 10$  m<sup>2</sup>
- 3)  $C = 25.13$  in,  $A = 50.27$  in
- 4)  $V = 80$  in<sup>3</sup>
- 5)  $V = 180$  ft<sup>3</sup>

#### Pythagorean Theorem

- 1)  $x = 12$  yd
- 2)  $x = 5$  mi.

# The Cartesian Coordinate System

1)

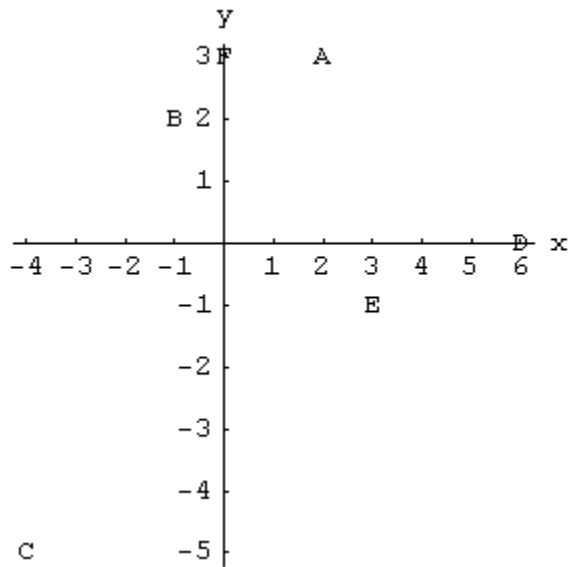

2) a)

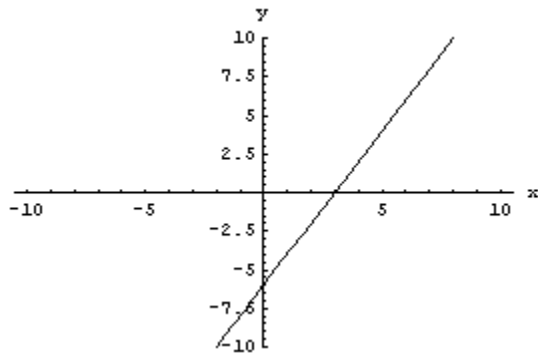

b)

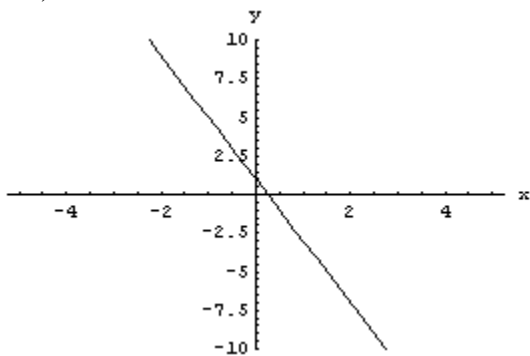

## Applications

- 1)  $23^{\circ}\text{F}$
- 2) 11.5 lb
- 3)  $256 < x < 625$
- 4) 9 are female
- 5) 36 were absent
- 6) 70.4%
- 7) 27 people are in line, 18 people left the line, approximately 5 people will leave the line after another 5 minutes (assuming 30% of the 18 people left will leave)
- 8) 78.82%
- 9) 65 hotdogs
- 10) 2%
- 11)  $-\$14.68$  (this is a negative balance)
- 12)  $\$8.25$
- 13) 300 mi
- 14)  $\$8.28$  saved
- 15)  $13/15$
- 16)  $(4.5)/(1/5)$
- 17) a)  $2x + 4 = x - 6$  ;  $x = -10$   
b)  $x - 3 = 4(x+8)$  ;  $x = -35/3$   
c)  $x/-4 = x/2 - 9$  ;  $x = 12$   
d)  $9(2x) = 40 - x$